

# Berklee**Shares.com**<sup>TM</sup>

## FREE music lessons from Berklee College of Music

### Producing with Pro Tools

Lesson 2:  
The Pro Tools Interface

This lesson is excerpted from an online course. While the navigation links on each page are not active, all of the multimedia interactions are. Have fun!

Check out [Berkleeshares.com](http://berkleeshares.com) for more lessons just like this one.



Berklee is offering free music lessons online designed to expand educational opportunities for musicians around the globe. The music lessons are available for free download from the [Berkleeshares.com](http://Berkleeshares.com) Web site and via a growing network of partner Web sites. These free music lessons are also available on digital file sharing networks. We encourage people to share our lessons with other musicians. While Berklee strongly disapproves of stealing copyrighted music online, we believe that file sharing offers new opportunities for musicians to learn, and to promote and distribute their work.



**Lesson 1**

- [Topic 1](#)
- [Topic 2](#)
- Topic 3**
- ➔ [Page 1](#)
- [Page 2](#)
- [Activity 1](#)
- [Activity 2](#)
- [Topic 4](#)
- [Topic 5](#)
- [Topic 6](#)
- [Activity 3](#)
- [Activity 4](#)
- [Topic 7](#)
- [Activity 5](#)
- [Topic 8](#)
- [Activity 6](#)
- [Topic 9](#)
- [Topic 10](#)
- [Topic 11](#)

---

**Course Contents**

- [Syllabus](#)
- [Bookmark](#)

---

**Communication**

- [Announcements](#)
- [Class list](#)
- [Discussion](#)
- [Chat](#)

## The Pro Tools Interface



### The Edit and Mix Windows

The Edit window displays audio waveforms, MIDI data, timeline information, and all of the tools for editing the waveforms and data. All other pertinent track data (volume, panning, solo, mute, blocks, and automation data) can also be viewed in this window. Almost all editing tasks are performed in this window.

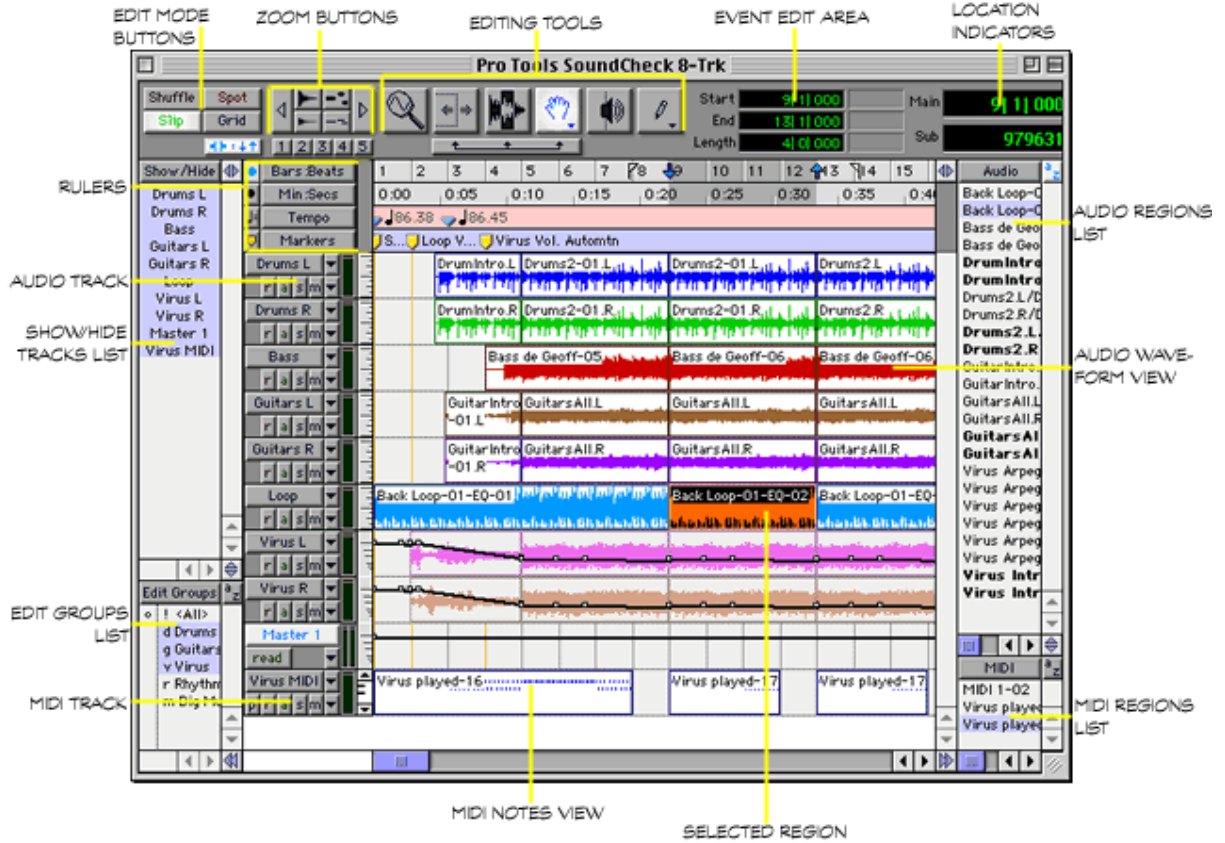

Pro Tools' Edit Window

The Mix window is designed like a mixing console and its primary function is for mixing multiple tracks down to a stereo (2-track) mix. There are vertical channel strips for each track, with sections for inserts, sends, input/output routing, and volume faders, as well as automation, pan, solo, and mute controls.

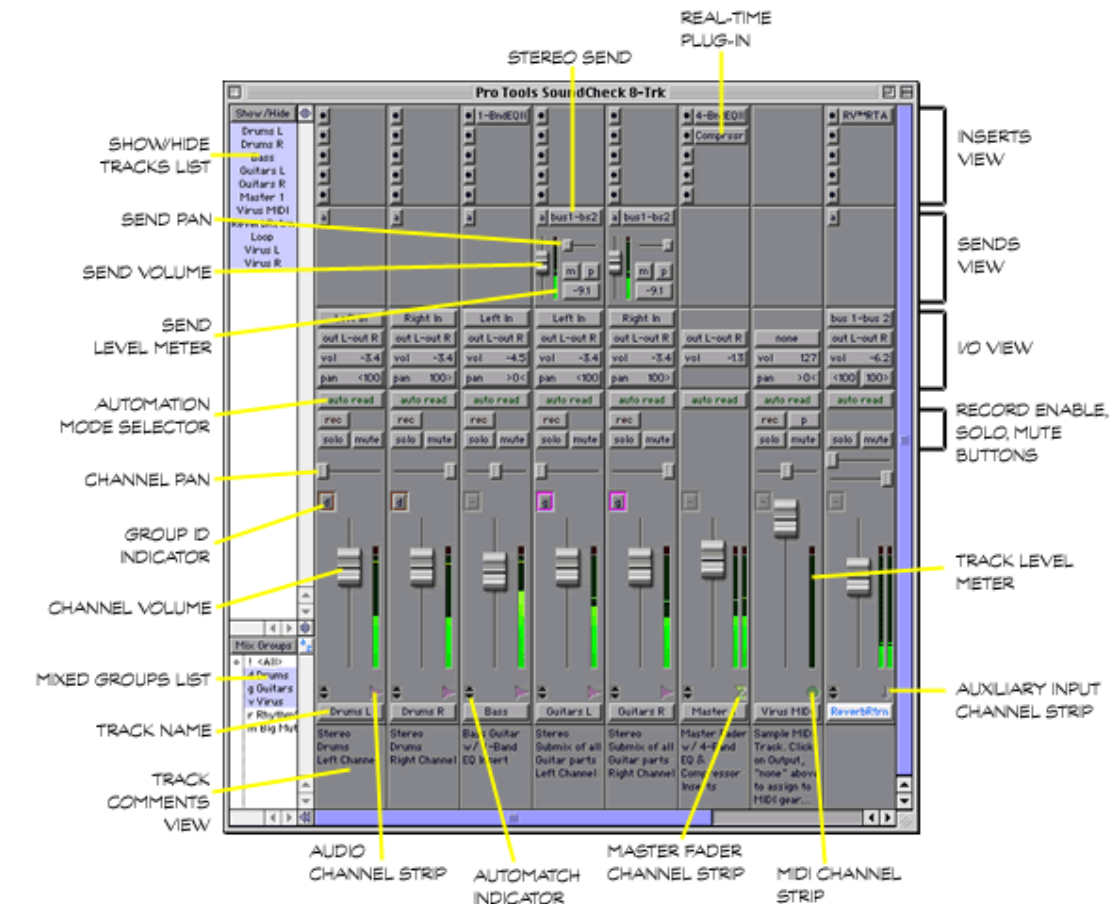

Pro Tools' Mix Window

<b>Lesson 1</b>
<a href="#">Topic 1</a>
<a href="#">Topic 2</a>
<b>Topic 3</b>
<a href="#">Page 1</a>
<b>Page 2</b>
<a href="#">Activity 1</a>
<a href="#">Activity 2</a>
<a href="#">Topic 4</a>
<a href="#">Topic 5</a>
<a href="#">Topic 6</a>
<a href="#">Activity 3</a>
<a href="#">Activity 4</a>
<a href="#">Topic 7</a>
<a href="#">Activity 5</a>
<a href="#">Topic 8</a>
<a href="#">Activity 6</a>
<a href="#">Topic 9</a>
<a href="#">Topic 10</a>
<a href="#">Topic 11</a>

<b>Course Contents</b>
<a href="#">Syllabus</a>
<a href="#">Bookmark</a>

<b>Communication</b>
<a href="#">Announcements</a>
<a href="#">Class list</a>
<a href="#">Discussion</a>
<a href="#">Chat</a>

## The Pro Tools Interface



### The Transport Window

The Transport window has controls like those on a cassette player or analog tape machine and is used to play, stop, record, fast-forward, and rewind your recorded material, as well as some more advanced functions. You can use the buttons in this window to control playback, recording, and navigation in Pro Tools.

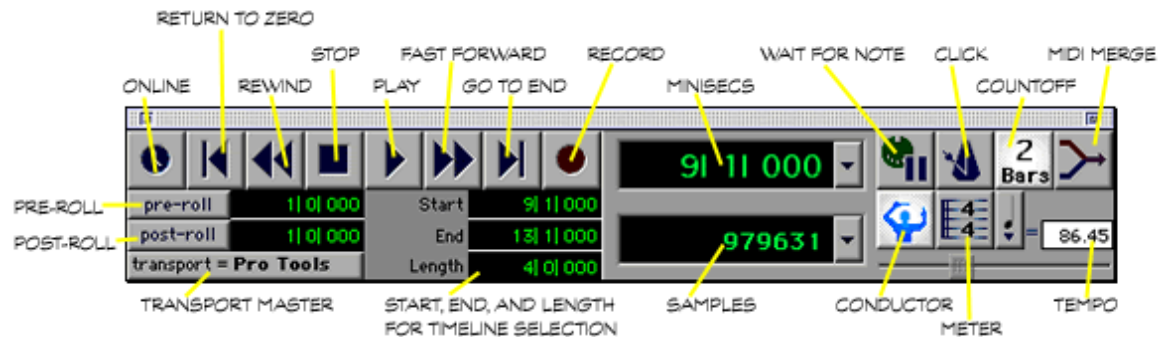

Pro Tools' Transport Window

To view any of these windows, select the window name from the appropriately titled Windows menu at the top of your Pro Tools screen.

In the following lessons, we'll cover all of the important features and functions found in these Pro Tools windows while keeping a broad perspective on the concepts and realities of producing music in your studio.

[Previous Page](#)

[Next Activity: Overview of the Production Process](#)

# Want more?

Guitar.  
Performance.  
**Production.**  
Songwriting & Arranging.  
Music Business.  
Theory, Harmony & Ear Training.

Study with the world-renowned professors of Berklee College of Music, on your own time, from anywhere in the world.

## Online Courses and Certificates from Berkleemusic



### Producing with Pro Tools

Learn Pro Tools using Digi Design's approved curriculum—only enhanced with greater depth and hands-on activities for Berkleemusic's online environment. Learn to record, editing, and mix, and get on the road to becoming a Pro Tools operator from home.



### Desktop Music Production for Mac or PC

Master the tools and techniques for producing great-sounding music at home ... and create high quality recordings ready for CD or MP3!

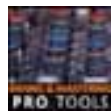

### Mixing and Mastering with Pro Tools

Gain a greater understanding of two key elements of music production by learning the Berklee approach to mixing and mastering using the Pro Tools software.



### Master Certificate in Producing

Gain a complete understanding of the concepts and production techniques, from fundamental-to-advanced, that you'll need to create, produce, and record professional-sounding arrangements in this 8-course certificate program.

[Learn More](#) ➔

## Books and DVDs from Berklee Press



### Producing in the Home Studio with Pro Tools

This best-selling book will show you how easy it is to produce music in your home or project studio using Digidesign's Pro Tools software.



### Producing Music with Digital Performer

No matter what your skill level, this complete guide is all you will need to produce music using MOTU's Digital Performer software.



### Recording and Producing in the Home Studio

No matter what software you use, this is the only guide you will need to set up your studio and record great music.



### Understanding Audio

Whether you are a musician setting up your first Pro Tools project studio, or you are a seasoned recording engineer or producer eager to find a reference that fills in the gaps in your understanding of audio, this book is for you.

[Learn More](#) ➔